

# INSTALLATION



## ICS090 Series Camclosure® Housing (Not Upgradeable)



C2477M (6/03)

# CONTENTS

<b>Section</b>	<b>Page</b>
IMPORTANT SAFEGUARDS AND WARNINGS .....	3
WELCOME .....	4
MODELS .....	4
REMOVE THE BUBBLE .....	5
INSTALL THE BACK BOX .....	6
INSTALLATION TO SURFACE OF A CEILING/WALL .....	6
IN-CEILING INSTALLATION – SUSPENDED CEILING .....	7
IN-CEILING INSTALLATION – FIXED CEILING/WALL .....	8
REINSTALL THE BUBBLE .....	9
SPECIFICATIONS .....	10
WARRANTY AND RETURN INFORMATION .....	11

## LIST OF ILLUSTRATIONS

<b>Figure</b>	<b>Page</b>
1 How to Remove the Bubble .....	5
2 Ceiling/Wall Installation .....	6
3 Concrete Ceiling/Wall Installation .....	6
4 Ceiling Tile Installation .....	7
5 How to Remove Surface Mount Ring from Back Box .....	7
6 In-Ceiling Installation to a Fixed Ceiling/Wall .....	8
7 How to Install the Bubble .....	9

## **IMPORTANT SAFEGUARDS AND WARNINGS**

1. Installation and servicing should be done only by qualified service personnel and conform to all local codes.
2. Unless the unit is specifically marked as a NEMA Type 3, 3R, 3S, 4, 4X, 6, or 6P enclosure, it is designed for indoor use only and must not be installed where exposed to rain and moisture.
3. Use only installation methods and materials capable of supporting four times the maximum specified load.

# WELCOME

Thank you for purchasing Pelco's ICS090 Series Camclosure® housing for indoor applications. The unit is easy to install and can be mounted to the surface of a ceiling/wall or recessed in a ceiling/wall.

The following is supplied with the ICS090 Series housing:

Qty.	Description
1	Assembled ICS090 Series housing (back box and bubble)
1	Adapter plate
2	8-32 x 1.00-inch Phillips pan head screws
2	8-32 x .750-inch self-tapping screws
2	8-32 x 2.50-inch self-tapping screws
2	10-32 x 1.50-inch self-tapping screws

## MODELS

ICS-090HNU	White housing with smoked dome
ICS-090BHNU	Black housing with smoked dome

---

**NOTE:** ICS090 Series housing models are not compatible with camera and lens packages and are not upgradeable.

---

## REMOVE THE BUBBLE

Turn the bubble counterclockwise and lift (refer to Figure 1). Place the bubble on a nonabrasive surface.

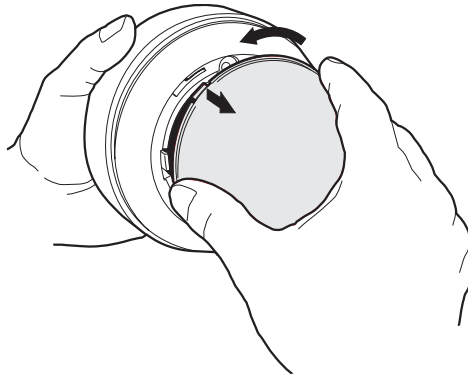

**Figure 1.** How to Remove the Bubble

## INSTALL THE BACK BOX

The installation methods for the ICS090 Series housing include the following:

- Mount to the surface of a ceiling/wall
- Install in a suspended ceiling
- Install in a fixed ceiling/wall

Select the best method for your installation and refer to the following pages for instructions.

### INSTALLATION TO SURFACE OF A CEILING/WALL

Using 6-32 toggle bolts, attach the surface mount ring and back box to the mounting surface (refer to Figure 2). For a concrete ceiling/wall installation, use 8-32 mounting hardware (refer to Figure 3).

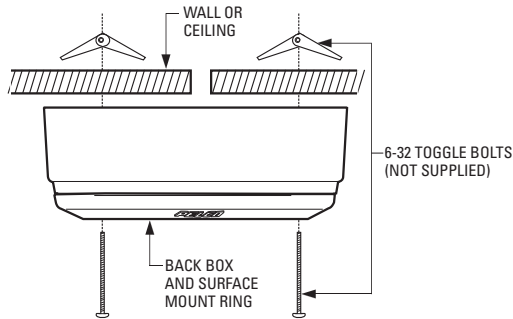

**Figure 2.** Ceiling/Wall Installation

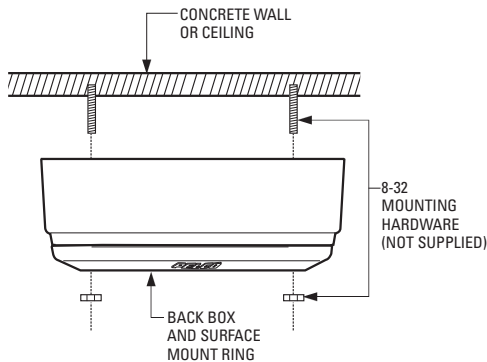
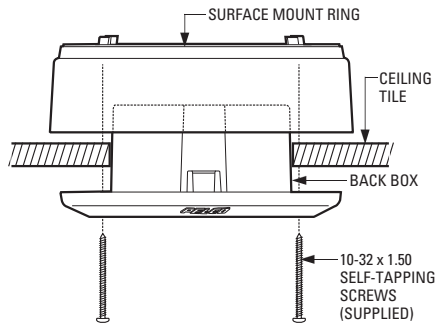

**Figure 3.** Concrete Ceiling/Wall Installation

## IN-CEILING INSTALLATION – SUSPENDED CEILING

Refer to Figure 4 for the following steps.

1. Remove the ceiling tile from the ceiling.
2. Cut a four-inch diameter hole in the ceiling tile.
3. Remove the surface mount ring from the back box. Refer to Figure 5 and do the following:
  - a. Place fingers on the circular marks located on the sides of the surface mount ring.
  - b. Pinch the sides.
  - c. Lift and remove the surface mount ring from the back box. Do not discard surface mount ring, because it is required to complete the installation.
4. Turn the surface mount ring upside down and place it on the inside of the ceiling tile.
5. Attach the back box to the ceiling tile and surface mount ring with the two 10-32 x 1.50-inch self-tapping screws (supplied).
6. Replace the ceiling tile.



**Figure 4. Ceiling Tile Installation**

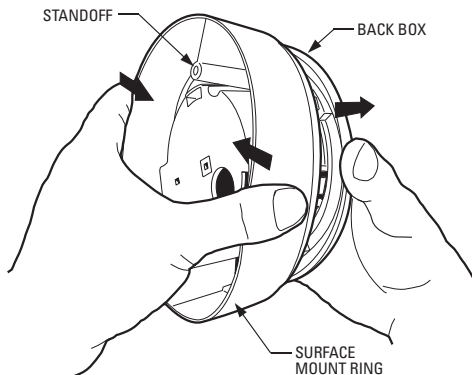
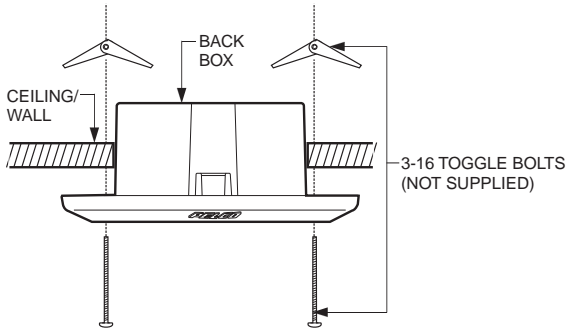

**Figure 5. How to Remove Surface Mount Ring from Back Box**

## IN-CEILING INSTALLATION – FIXED CEILING/WALL

Refer to Figure 6 for the following steps.

1. Cut a four-inch diameter hole in the ceiling/wall.
2. Remove the surface mount ring from the back box. Refer to Figure 5 and do the following:
  - a. Place fingers on the circular marks located on the sides of the surface mount ring.
  - b. Pinch the sides.
  - c. Lift and remove the surface mount ring from the back box.
3. Using 3-16 toggle bolts, attach the back box to the mounting surface.



**Figure 6.** In-Ceiling Installation to a Fixed Ceiling/Wall



## REINSTALL THE BUBBLE

To install the bubble refer to Figure 7 and do the following:

1. Align the standoffs of the bubble with the slots of the back box.
2. Turn the bubble clockwise until it locks in place.

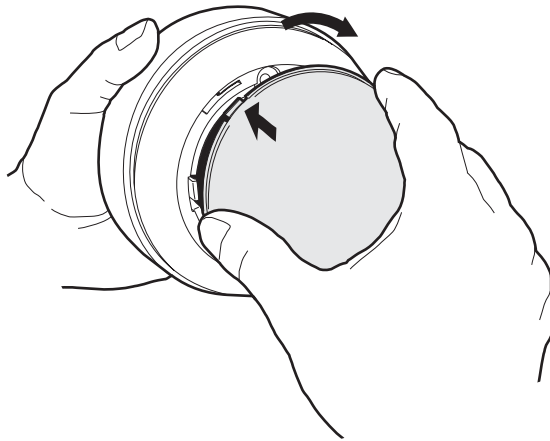

**Figure 7.** How to Install the Bubble

# SPECIFICATIONS

## General

### Construction

Back Box and

Surface Mount Ring: ABS plastic

Bubble: Polycarbonate

Finish: White

Environment: Indoor

### Weight

Unit: .52 lb (.24 kg)

Shipping: 2 lb (.91 kg)

*(Design and product specifications subject to change without notice.)*

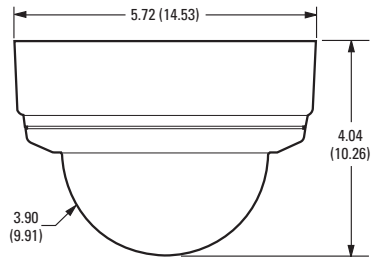
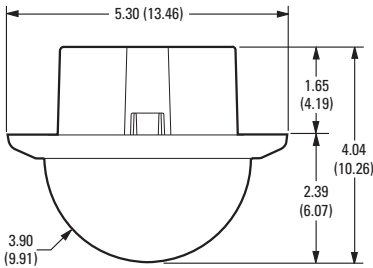

**NOTE:** VALUES IN PARENTHESES ARE CENTIMETERS; ALL OTHERS ARE INCHES.

# WARRANTY AND RETURN INFORMATION

## WARRANTY

Pelco will repair or replace, without charge, any merchandise proved defective in material or workmanship for a period of one year after the date of shipment. Exceptions to this warranty are as noted below:

- Five years on Pelco manufactured cameras (CC3500/CC3600/CC3700 and MC3500/MC3600 Series); two years on all other cameras.
- Three years on Genex® Series (multiplexers, server, and keyboard) and 090 Series Camclosure® Camera System.
- Two years on 100/150, 200 and 300 Series Camclosure® Camera Systems.
- Two years on cameras and all standard motorized or fixed focal length lenses.
- Two years on Legacy®, CM6700/CM6800/CM6800E/CM8500/CM9500/CM9740/CM9760 Matrix, DF5 and DF8 Series Fixed Dome products.
- Two years on Spectra®, Esprit®, and PS20 Scanners, including when used in continuous motion applications.
- Two years on Esprit and WW5700 series window wiper (excluding wiper blades).
- Eighteen months on DX Series digital video recorders.
- One year (except video heads) on video cassette recorders (VCRs). Video heads will be covered for a period of six months.
- Six months on all pan and tilts, scanners or preset lenses used in continuous motion applications (that is, preset scan, tour and auto scan modes).

Pelco will warrant all replacement parts and repairs for 90 days from the date of Pelco shipment. All goods requiring warranty repair shall be sent freight prepaid to Pelco, Clovis, California. Repairs made necessary by reason of misuse, alteration, normal wear, or accident are not covered under this warranty.

Pelco assumes no risk and shall be subject to no liability for damages or loss resulting from the specific use or application made of the Products. Pelco's liability for any claim, whether based on breach of contract, negligence, infringement of any rights of any party or product liability, relating to the Products shall not exceed the price paid by the Dealer to Pelco for such Products. In no event will Pelco be liable for any special, incidental or consequential damages (including loss of use, loss of profit and claims of third parties) however caused, whether by the negligence of Pelco or otherwise.

The above warranty provides the Dealer with specific legal rights. The Dealer may also have additional rights, which are subject to variation from state to state.

If a warranty repair is required, the Dealer must contact Pelco at (800) 289-9100 or (559) 292-1981 to obtain a Repair Authorization number (RA), and provide the following information:

1. Model and serial number
2. Date of shipment, P.O. number, Sales Order number, or Pelco invoice number
3. Details of the defect or problem

If there is a dispute regarding the warranty of a product which does not fall under the warranty conditions stated above, please include a written explanation with the product when returned.

Method of return shipment shall be the same or equal to the method by which the item was received by Pelco.

## RETURNS

In order to expedite parts returned to the factory for repair or credit, please call the factory at (800) 289-9100 or (559) 292-1981 to obtain an authorization number (CA number if returned for credit, and RA number if returned for repair).

All merchandise returned for credit may be subject to a 20% restocking and refurbishing charge.

Goods returned for repair or credit should be clearly identified with the assigned CA or RA number and freight should be prepaid. Ship to the appropriate address below.

*If you are located within the continental U.S., Alaska, Hawaii or Puerto Rico:*

Service Department  
Pelco  
3500 Pelco Way  
Clovis, CA 93612-5699

*If you are located outside the continental U.S., Alaska, Hawaii or Puerto Rico:*

### **Intermediate Consignee**

American Overseas Air Freight  
320 Beach Road  
Burlingame, CA 94010  
USA

### **Ultimate Consignee**

Pelco  
3500 Pelco Way  
Clovis, CA 93612-5699  
USA

© Pelco, the Pelco logo, Spectra, Genex, Legacy, Esprit, and Camclosure are registered trademarks of Pelco.  
© Copyright 2003, Pelco. All rights reserved.

## REVISION HISTORY

Manual #	Date	Comments
C2477M	6/03	Original version.



World Headquarters  
3500 Pelco Way  
Clovis, California 93612 USA

USA & Canada  
Tel: 800/289-9100  
Fax: 800/289-9150

International  
Tel: 1-559/292-1981  
Fax: 1-559/348-1120

**[www.pelco.com](http://www.pelco.com)**

ISO9001